

- Specify Finish Required: Satin finish
 Satin finish with peened gripping surface; add suffix .99 to model number

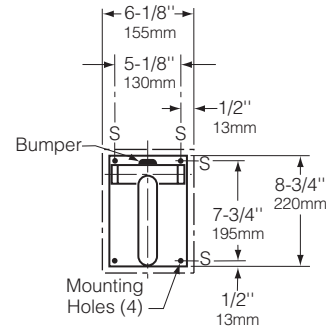

Patented



Grab Bar Backplate

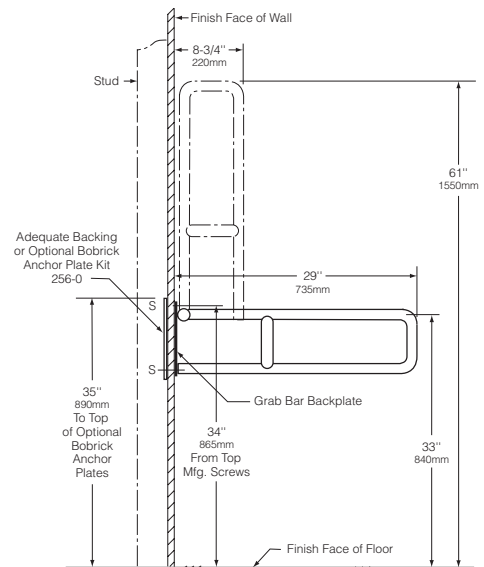
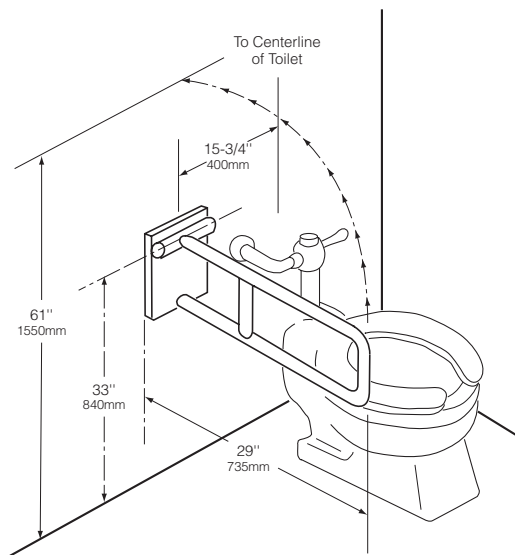

MATERIALS:

Grab Bar — 18-8 S, type-304, 18-gauge (1.2mm) stainless steel tubing with satin finish. 1-1/4 (32mm) outside diameter. Ends are heliarc welded to flanges.

Backplate — 18-8 S, type-304, 3/16" (5mm) thick, satin-finish stainless steel with four screw holes for attachment to wall.

OPERATION:

Swing-up grab bar is manually raised for approach or departure and lowered to horizontal position for support; once grab bar is raised more than 45° from horizontal position, counterweighted design prevents grab bar from falling back down to full horizontal position.

continued . . .

STRENGTH:

Swing-up grab bar can support loads in excess of 250 pounds (113kg) if properly installed, complying with barrier-free accessibility guidelines (including ADAAG in the U.S.A.) for structural strength.

Caution: *Grab bars are no stronger than the anchors and walls to which they are attached and, therefore, must be firmly secured in order to sustain the loads for which they are intended.*

INSTALLATION:

Provide concealed anchor device or backing as specified or required in accordance with local building codes before wall is finished. Fasten grab bar to anchor device or backing. Concealed anchor devices and mounted screws are not included with Bobrick grab bars and must be specified as an optional accessory.

SPECIFICATION:

Grab bar shall be type-304 stainless steel with satin finish. Grab bar shall have 18-gauge (1.2mm) wall thickness and 1-1/4" (32mm) outside diameter. Flanges shall be 3/16" (5mm) thick stainless steel plate, 3" (75mm) diameter, and equipped with three screw holes for attachment to wall or floor. Swing-up grab bar shall be manually raised for approach or departure and lowered to horizontal position for support; counterweighted design shall prevent grab bar from falling back down to full horizontal position once grab bar is raised more than 45° from horizontal position. Grab bar shall comply with barrier-free accessibility guidelines (including ADAAG in the U.S.A.) for structural strength. Manufacturer's service and parts manual shall be provided to the building owner/manager upon completion of project.

Swing-Up Grab Bar shall be Model _____ (insert model number) of Bobrick Washroom Equipment, Inc., Clifton Park, New York; Jackson, Tennessee; Los Angeles, California; Bobrick Washroom Equipment Company, Scarborough, Ontario; Bobrick Washroom Equipment Pty. Ltd., Australia; and Bobrick Washroom Equipment Limited, United Kingdom.