

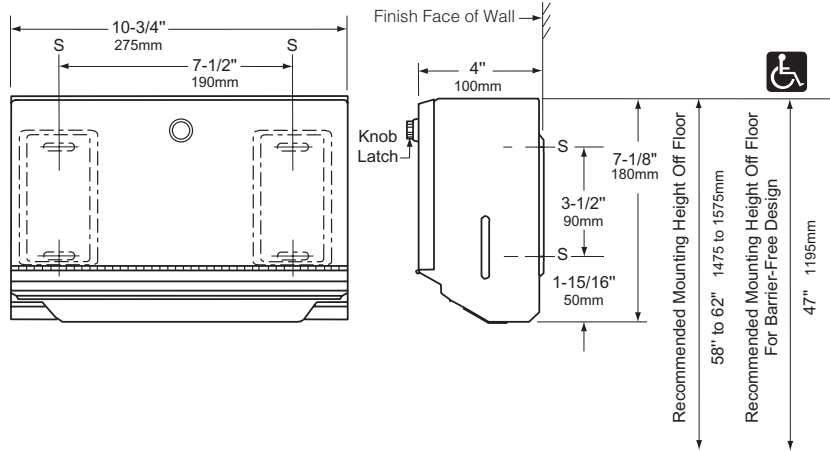

Technical Data

# SURFACE-MOUNTED PAPER TOWEL DISPENSER

# B-2621



## MATERIALS:

**Cabinet** — 18-8 S, type-304, 22-gauge (0.8mm) stainless steel. All-welded construction. Exposed surfaces have satin finish. Towel tray has hemmed opening to dispense paper towels without tearing.

**Door** — 18-8 S, type-304, 22-gauge (0.8mm) stainless steel with satin finish. Secured to cabinet with a full-length stainless steel piano-hinge. Equipped with a knob latch.

## OPERATION:

Unit dispenses C-fold and multifold paper towels 3-1/8" to 3-13/16" (79–97mm) deep without adjustment or use of adapters. Slots in sides of cabinet indicate refill time. Capacity: 200 C-fold or 275 multifold paper towels. To dispense narrower towels 2-1/2" to 3-1/8" (64–79mm) deep, order Bobrick Internal Towel Tray Adapter Kit, Part No. 5262-25.

## INSTALLATION:

Mount unit on wall with four #10 x 1-1/4" (4.8 x 32mm) sheet-metal screws (not furnished) at points indicated by an *S*. For plaster or dry wall construction, provide concealed backing to comply with local building codes, then secure unit with sheet-metal screws. For other wall surfaces, provide fiber plugs or expansion shields for use with sheet-metal screws, or provide 1/8" (3mm) toggle bolts or expansion bolts.

## SPECIFICATION:

Surface-mounted paper towel dispenser shall be type-304 stainless steel with all-welded construction; exposed surfaces shall have satin finish. Door shall be secured to cabinet with a full-length stainless steel piano-hinge and equipped with a knob latch. Paper towel tray shall have hemmed opening to dispense paper towels without tearing. Unit shall be capable of dispensing 200 C-fold or 275 multifold paper towels without adjustment or use of adapters. Manufacturer's service and parts manual shall be provided to the building owner/manager upon completion of project.

**Surface-Mounted Paper Towel Dispenser shall be Model B-2621 of Bobrick Washroom Equipment, Inc., Clifton Park, New York; Jackson, Tennessee; Los Angeles, California; Bobrick Washroom Equipment Company, Scarborough, Ontario; Bobrick Washroom Equipment Pty. Ltd., Australia; and Bobrick Washroom Equipment Limited, United Kingdom.**