

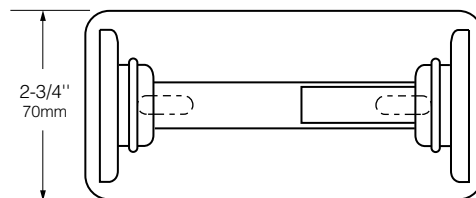

Technical Data

# SINGLE-ROLL TOILET TISSUE DISPENSER WITH CONTROLLED DELIVERY

# B-264

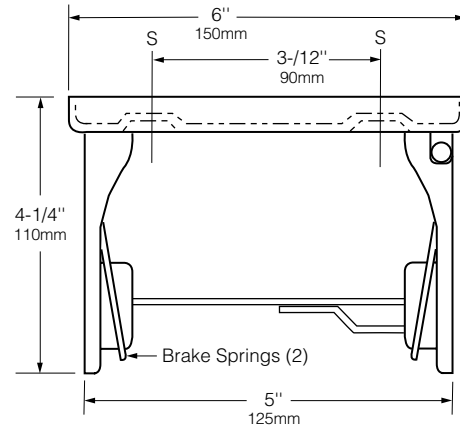

## MATERIALS:

Heavy-gauge chrome-plated steel with bright polished finish. Mounting bracket is 18-gauge (1.2mm). Equipped with a vandal-resistant self-locking mechanism and two heavy-duty brake springs.

## OPERATION:

Heavy-duty brake springs provide controlled delivery. Toilet tissue roll will not spin freely. Eliminates waste. Accommodates one standard-core toilet tissue roll up to 4-1/2" (115mm) diameter. Toilet tissue roll cannot be removed from holder until empty.

## INSTALLATION:

Mount unit on wall or toilet partition with two sheet-metal screws, furnished by manufacturer, at points indicated by an S.

For plaster or dry wall construction, provide concealed backing to comply with local building codes, then secure unit with sheet-metal screws furnished. For other wall surfaces, provide fiber plugs or expansion shields for use with sheet-metal screws, or provide 1/8" (3mm) toggle bolts or expansion bolts.

For partitions with particle-board or other solid core, secure with sheet-metal screws, or provide through-bolts, nuts, and washers. For hollow-core metal partitions, provide solid backing into which sheet-metal screws can be secured.

## SPECIFICATION:

Single-roll toilet tissue dispenser shall be heavy-gauge chrome-plated steel with bright polished finish. Unit shall be equipped with a vandal-resistant self-locking mechanism, provide controlled delivery operation, and accommodate one standard-core toilet tissue roll up to 4-1/2" (115mm) diameter. Manufacturer's service and parts manual shall be provided to the building owner/manager upon completion of project.

**Single-Roll Toilet Tissue Dispenser shall be Model B-264 of Bobrick Washroom Equipment, Inc., Clifton Park, New York; Jackson, Tennessee; Los Angeles, California; Bobrick Washroom Equipment of Canada Ltd., Scarborough, Ontario; Bobrick Washroom Equipment Pty. Ltd., Australia; Bobrick Washroom Equipment Limited, United Kingdom.**