

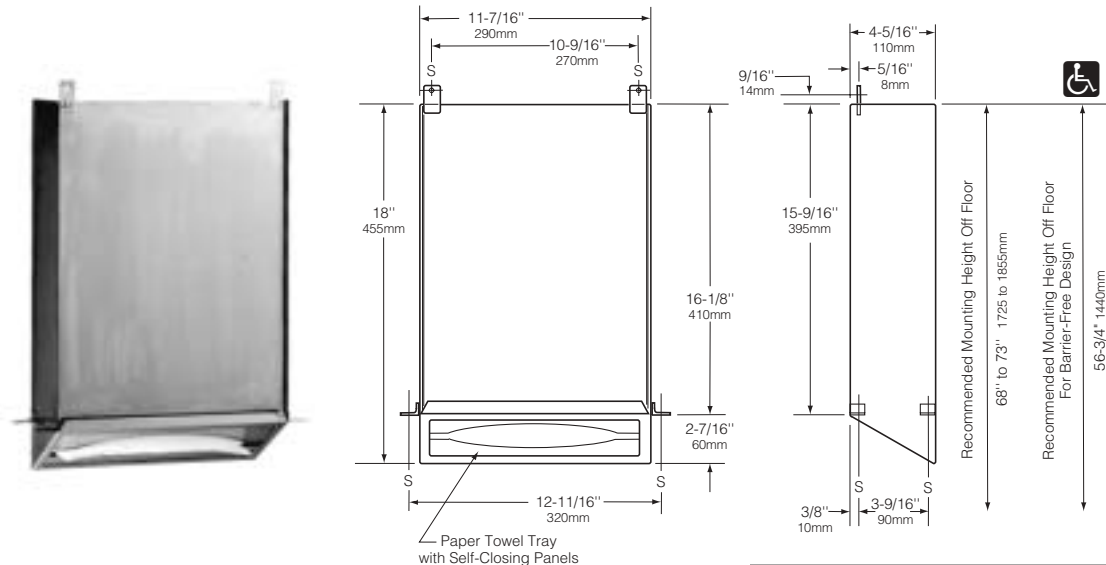

# Technical Data

# RECESSED PAPER TOWEL DISPENSER (with Towel Cabinet Concealed in Wall)

# B-318



### Rough Wall Opening

12" (305mm) wide.

18-1/4" (465mm) high to accept cabinet height *plus* 6" (152mm) minimum clearance below cabinet.

4-1/2" (114mm) minimum recessed depth *plus* thickness of wall finish.

### MATERIALS:

**Cabinet** — 18-8 S, type-304, heavy-gauge stainless steel. All-welded construction.

**Paper Towel Tray** — 18-8 S, type-304, heavy-gauge stainless steel with satin finish. Equipped with two self-closing piano-hinged panels. Capacity: 600 C-fold or 800 multifold paper towels.

### OPERATION:

Paper towel dispenser will dispense C-fold or multifold paper towels without adjustment or the use of adapters. Only the paper towel tray is visible when properly installed. Unit is loaded from bottom by pushing towels up through self-closing panels of paper towel tray.

*Designer's Notes:* Model B-318 is designed for installation in wall prior to installation of surface-mounted framed or unframed mirror (not furnished as part of Model B-318). Bobrick B-290 Series stainless steel angle-frame mirrors are suggested for installation in combination with Model B-318. For standard installations, it is recommended that the unit be located between two lavatories. Installation in a non-mirror side wall is recommended where access is needed by physically disabled persons.

### INSTALLATION:

Provide framed rough wall opening 12" (305mm) wide; height should be at least 24-1/4" (615mm), allowing 6" (152mm) minimum recess space below unit for access to towels. Minimum recessed depth required is 4-1/2" (114mm) plus thickness of wall finish. Allow clearance for construction features that may protrude into rough wall opening from opposite wall. Coordinate with mechanical engineer to avoid pipes, vents, and conduits. Mount unit in wall opening with shims between framing and mounting tabs at four points indicated by an *S*, then secure unit to framing with #8 x 1-1/4" (4.2 x 32mm) sheet-metal screws (not furnished).

### SPECIFICATION:

Recessed paper towel dispenser shall be type-304 stainless steel with all-welded construction; exposed surfaces shall have satin finish. Paper towel tray shall be equipped with two self-closing piano-hinged panels. Unit shall dispense 600 C-fold or 800 multifold paper towels without adjustment or use of adapters. Manufacturer's service and parts manual shall be provided to the building owner/manager upon completion of project.

**Recessed Paper Towel Dispenser shall be Model B-318 of Bobrick Washroom Equipment, Inc., Clifton Park, New York; Jackson, Tennessee; Los Angeles, California; Bobrick Washroom Equipment Company, Scarborough, Ontario; Bobrick Washroom Equipment Pty. Ltd., Australia; and Bobrick Washroom Equipment Limited, United Kingdom.**