



WWW.BOBRICK.COM

Technical Data

RECESSED HEAVY-DUTY SOAP DISH (FOR STUD WALLS)

B-4380

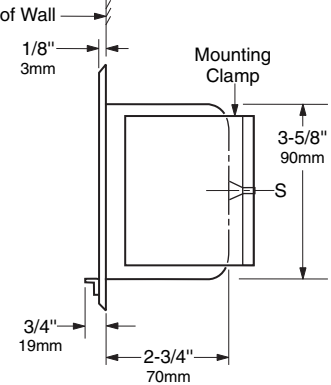
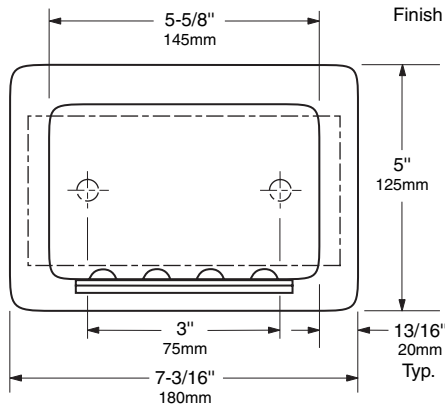

Rough Wall Opening
5-15/16" (150mm) wide
4" (102mm) high
4" (102mm) minimum recessed depth

MATERIALS:

Shell & Flange — 18-8 S, type-304, 19-gauge (1.0mm) stainless steel with matte polished finish. Drawn and beveled, one-piece, seamless construction with two countersunk mounting holes.

Retaining Lip — 18-8 S, type-304, 22-gauge (0.8mm) stainless steel with matte polished finish.

INSTALLATION:

Provide framed rough wall opening 5-15/16" wide x 4" high (150 x 102mm). Minimum recessed depth to finish face of wall is 4" (102mm). Insert unit into rough wall opening and secure with two sheet-metal screws (not furnished). Backing must comply with local building codes.

SPECIFICATION:

Recessed heavy-duty soap dish shall be type-304 stainless steel with matte polished finish. Shell and flange shall be 19 gauge (1.0mm) with drawn and beveled, one-piece, seamless construction. Unit shall be equipped with a 22-gauge (0.8mm) retaining lip and furnished with machine screws for installation in stud walls. Manufacturer's service and parts manual shall be provided to the building owner/manager upon completion of project.

Recessed Heavy-Duty Soap Dish shall be Model B-4380 of Bobrick Washroom Equipment, Inc., Clifton Park, New York; Jackson, Tennessee; Los Angeles, California; Bobrick Washroom Equipment Company, Scarborough, Ontario; Bobrick Washroom Equipment Pty. Ltd., Australia; and Bobrick Washroom Equipment Limited, United Kingdom.