



WWW.BOBRICK.COM

Technical Data

VANDAL-RESISTANT SOAP DISH (SECURED FROM FRONT)

B-973

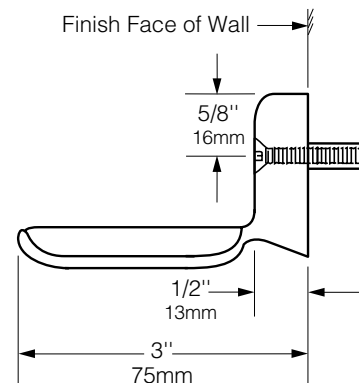
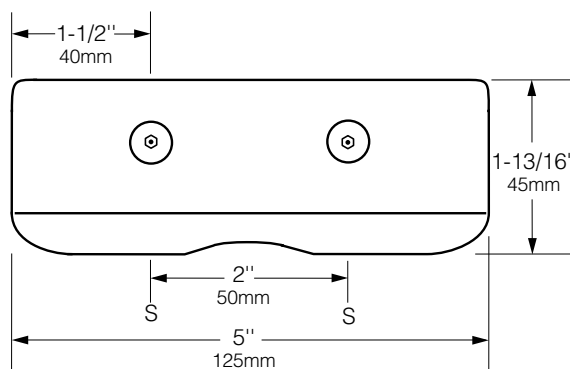

MATERIALS:

Extra-heavy cast bronze. Exposed surfaces have bright polished chrome-plated finish. All edges are rounded for safety. Fully enclosed back prevents concealment of contraband. Raised center for self-draining.

INSTALLATION:

Secure unit to wall at all points indicated by an S. Unit has countersunk screw holes and is furnished with two 1/4-20 x 1 1/2" (6 x 38mm) tamper-resistant, flat-head, hex-socket, stainless steel machine screws and a security hex key for installation. Expansion shields are not furnished by manufacturer.

SPECIFICATION:

Soap dish shall be extra-heavy cast bronze; exposed surfaces shall have bright polished chrome-plated finish. Unit shall have fully enclosed back to prevent concealment of contraband. Unit shall be furnished with tamper-resistant mounting screws. Manufacturer's service and parts manual shall be provided to the building owner/manager upon completion of project.

Soap Dish shall be Model B-973 of Bobrick Washroom Equipment, Inc., Clifton Park, New York; Jackson, Tennessee; Los Angeles, California; Bobrick Washroom Equipment Company, Scarborough Ontario; Bobrick Washroom Equipment Pty. Ltd., Australia; and Bobrick Washroom Equipment Limited, United Kingdom.